

# 6U VPX Development Backplane 1.0 Inch Pitch 5-Slot Fabric Mappable

## Features

- ◆ 5-Slot – BKP6-DIS05-11.2.16-n
- ◆ 6U OpenVPX compliant, 1” pitch
- ◆ Topology includes Utility Plane with Pwr/Gnd, IPMB, and PCI express daisy chain (See rear side map)
- ◆ Backplane supports additional topologies via Dawn’s Fabric Mapping Module\* (FMM\*) micro-overlays
- ◆ Additional mapping such as custom PCIe, SRIO, and Ethernet is available and may be added to backplane at time of order
- ◆ Ultra-high performance stripline / differential signal design.
- ◆ User configurable slot key rotation for VPX Cards and RTM.
- ◆ Design supports RTM connectors at all rear slots.
- ◆ Tyco Connectors may be partially populated for cost savings.
- ◆ Integrated connectors for RuSH system monitor interface.

\* = Patent Applied For

## Overview

According to the VITA65 specification, BKP6-DIS05-11.2.16-n “backplane profiles are intended for a development environment. Some systems might be able to deploy with these backplanes. This backplane contains 5 Payload Slots in a distributed 5-Slot mesh in which each slot is directly connected to every other payload slot.” There is no Control Plane or Switch Slot. Peripheral Slot Profile for all slots is SLT6-PER-4F-10.3.1

Dawn’s implementation of this profile allows for a choice of RTM connectors or use of FMM\* modules. Custom FMMs\* loaded with standard COTS connectors, can provide low profile signal breakout for applications where transition module cost and size do not work.

See separate FMM data sheet for specifics.

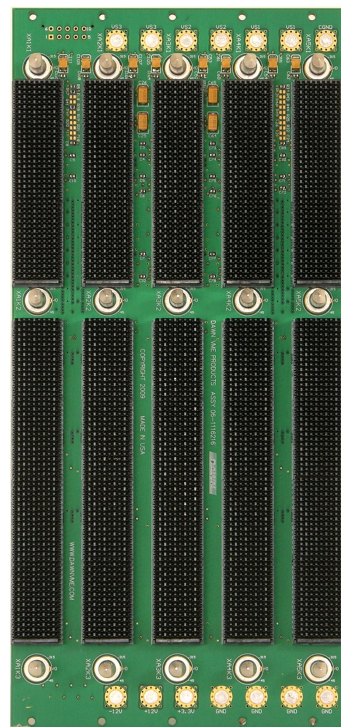

## Specifications

### Compliance

Dawn’s 7135 Series VPX Backplanes are designed to be compliant with the following released standards and June 2010 state of draft specifications: VITA 46.0, VITA 46.1, VITA 46.3, VITA 46.4, VITA 46.6, VITA 46.7, VITA 46.9, VITA 46.10, VITA 46.11, VITA 48.0(REDI), VITA 48.1(REDI Air Cooling), VITA 48.2(REDI Conduction Cooling), VITA65.0(Open VPX) ready

### Mechanical

**Compatibility:** VITA46.0,.3,.4,.7,.9 / VITA48, VITA65 (OpenVPX) ready

**PCB Material:** PCL-FRP-370HR RoHS compliant

**PCB Design:** 22-Layer, Ultra high performance, impedance controlled stripline / differential signal routing.

**Power/Ground Planes:** Multiple, 2 oz. copper layers for each VSx supply.

**Signal:** 1 oz. copper

**Finish:** LPI Green Solder mask

**Plating:** Gold over Nickel (ENIG)

**Dimensions:** 10.317” x 4.765”, 0.212” Thick.

**Weight:** 3.00 Lbs Estimated fully populated

### Electrical

**Power Input:** #6 Ring Terminals on 6x32 Press-fit power studs

**Max. Power Input per Rail:** Vs1, Vs2, Vs3 = 100A

**Max. Concurrent Power (Vs1, Vs2, Vs3) per Slot = 22A**

**Continuous Distributed Power per Slot:** VS1 (+12v)=14A, VS2 (+12v)=14A, VS3 (+5v) =15A.

**Maskable Reset:** Selectable connection of maskable reset to each slot.

**System slot:** Select any VPX slot, to be system slot, via jumper.

### Environmental

**Storage Temperature:** -40°C to +105°C

**Operating Temperature:** -40°C to +105°C

**Humidity:** <95% non-condensing

# Ordering Information

## Order P/N 06-1117135

Note: P/N 06-1117135 ships with DEV-4135 Development Chassis and includes all RTM connectors and no FMM's

(Contact Factory for details if you would like additional topology added to this backplane)

BKP6-DIS05-11.2.16.x

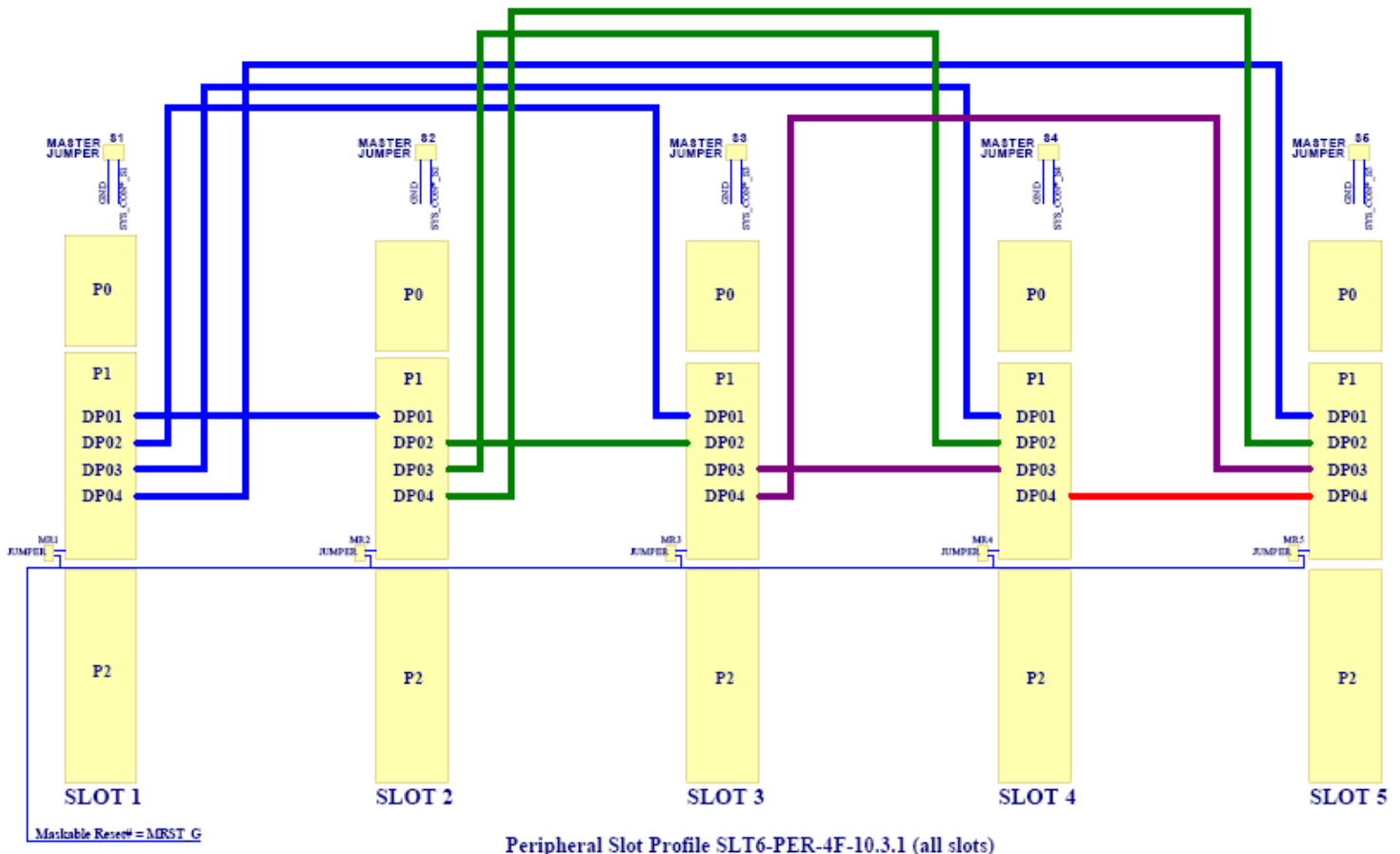

### Topology of 5 Slot – BKP6-DIS05-11.2.16-n

#### Other Products and Services Available from Dawn:

- Conceptualization, design and production of custom enclosures and backplanes.
- Conduction or Convection Cooled ATR Chassis Design and production
- Thermal Design and Analysis
- Microprocessor based sensor monitoring and control.
- Technologies Supported: cPCI 2.1, cPCI 2.16, PXI, VME, VME64, VME64x, VXI, VXS(Vita 41), VPX(Vita46), VPX REDI(Vita 48), OpenVPX(Vita 65)

#### About Dawn:

Dawn is a certified veteran owned small business based in Fremont, CA, serving the real time computer and embedded systems market.

Dawn specializes in conceptualization, design, and production of high technology enclosures and backplanes for thousands of companies within the commercial, industrial, aerospace and defense markets.

Our customers consist of Major OEM's, National Labs, Universities, all aerospace and defense contractors, and the U.S. Government.

Our Quality Standards are designed and tuned to support the needs of the vast market we serve.

Dawn celebrated its 25<sup>th</sup> anniversary of business on February 19, 2010.