

Conduction Cooled Enclosure for VPX 3U UAV Applications

Features

- ◆ Ideal packaging solution for UAV applications
- ◆ Extremely robust, bullet proof design
- ◆ Fully integrated power supply, backplane, I/O in one box
- ◆ 6-Slots of 3u VPX on 1" pitch (OpenVPX Ready)
- ◆ Full environmental sealing per DO-160E
- ◆ Vita 48.2 Conduction Cooled slot compatible
- ◆ Integrated power supply is bulkhead mounted to rear wall
- ◆ RuSH enhanced power supply actively monitors:
 - Voltage and Current on each power rail
 - Temperature & (Humidity - optional)
 - Firmware controlled power sequencing
 - I2C communications over management plane
- ◆ Rigid front panel interface eliminates wiring challenges
- ◆ Backplane overlays enable PMC/XMC to I/O customization
- ◆ I/O is mappable between backplane and rigid I/O board using Dawn's patented FMM modules
- ◆ Best price-performance-delivery lead time available to the market whether prototype or production

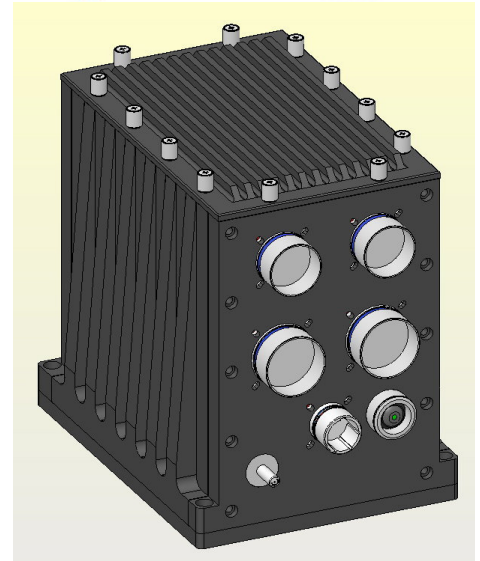

Overview

Dawn created the "CUBE" family of products to provide for the needs of the UAV market. Available in 1 through 6 slots, each chassis is shipped complete with backplane, power system and I/O ready for your addition of boards.

Backplane topology and I/O to panel connectors may be mapped into the system at time of order by using Dawn's patented and performance "Eye-tested" Fabric Mapping Module Technology.

The CUBE chassis provides a bullet proof sealed environment for your application and boards to run in. Each design is thermally modeled using the latest in 3D modeling and thermal analysis CAD software.

Dawn can model your planned configuration and determine exact thermal performance before you place your order.

Dawn's 3U form factor conduction cooled chassis for cold plate deployment is designed for all rugged environments; Airborne, Land and Sea.

Conduction cooled base coupled, via short and efficient path, provides for optimum cooling. Maximum power dissipation depends on cold plate.

RuSH enhanced 3u conduction cooled power supply monitors system critical performance parameters including Voltage, Current, and Temperature. Power supply startup is under firmware controlled and may be factory modified to operate with startup sensitive boards.

The RuSH monitor is interfaced into the OpenVPX IPMB (I2C) management plane, providing communication link up with system cards.

Specifications

Mechanical

Extended Shock and Vibration Per MIL-STD-810E

Mounting: 1" or 1/2" grid cold plate.

Compatibility: 3u VITA46 & VITA65 (OpenVPX) card compatible

Dimensions: 9.0"L x 6.0"W x 7.62" H

Weight: Approximately 16.5 Lbs without 3U Modules

Backplane

PCB Design: 18-Layer, High performance, FMM Overlay Ready

Power/Ground Planes: Multiple, 2 oz. copper

Card Guide: Chassis Ground connected for Card protection.

Power per Slot: 20A per power rail (VITA 46/65 - VS1,VS2,VS3).

Power Supply

PCB Design: 8-Layer, 2oz copper, High performance

Input Voltage: 12VDC, 28VDC, or 48VDC Nominal

Voltage Rails: +12V (VS1), +3.3V (VS2), +5V (VS3),

Aux+12V, Aux-12V, Aux+3.3V, VBAT (+3.0V typical)

Output Voltage/Current Vs1-Vs3, Aux_V/A @ Nominal Input:

12VDC: (Vs1)12V/12.5A, (Vs2)3.3V/20A, (Vs3)5V/30A

28/48VDC: (Vs1)12V/16.7A, (Vs2)3.3V/30A, (Vs3)5V/40A

12/28/48VDC: (Aux_3.3V/4A, Aux_+12V/4A, Aux_-12V/3A

Wattage Max +5V rail: 150W@12V Input, 200W@28 or 48 V input

Wattage Max +12V rail: 150W@12V Input, 200W@28 or 48 V input

Total Maximum Power: 240W@12V Input, 400W@28 or 48 V input

Ripple: 50mVp-p on +3.3V and +5V, 150mVp-p on +12V and -12V

Isolation Voltage: Input to Output (1500V)

Front I/O panel

I/O panel to Backplane interfaced via shielded differential connectors for applications from 3.125 Gb/s to 10+ Gb/s. I/O panel connectors can be linked to SMA and other RF connectors for application enhancement.

Environmental

Storage Temperature: -40°C to +100°C

Operating Temperature: -40°C to +85°C (Review chassis and card thermal testing specs for specific applications).

Maximum power dissipation depends on cold plate.

Full environmental sealing per DO-160E

EMI Shielding meets MIL-STD-461E

Ordering Information

Dawn P/N 11-1017296-WXYZ

W = Power Option

0=No power supply
1 = 9 to 18VDC
2 = 18 to 36VDC
3 = 36 to 72VDC
4 = 90-384VAC, 50-400Hz

X Y Z = Customer Configuration

Please contact sales@dawnvme.com with any questions you may have. Additional information is available for the power supply and fabric mapping modules used for backplane topology and I/O. If you would like to find out how well your application would perform thermally in this product, please submit a list of manufacturer part numbers and specify where the cards will be installed. Dawn will return a quote for performing a thermal analysis with report for your exact configuration.

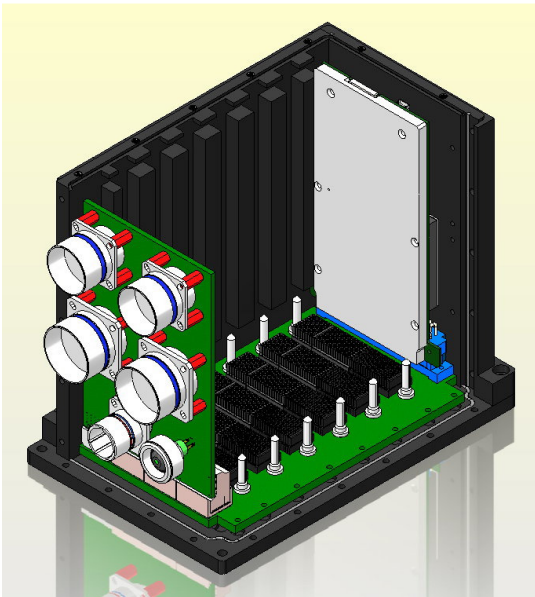

Open Front View

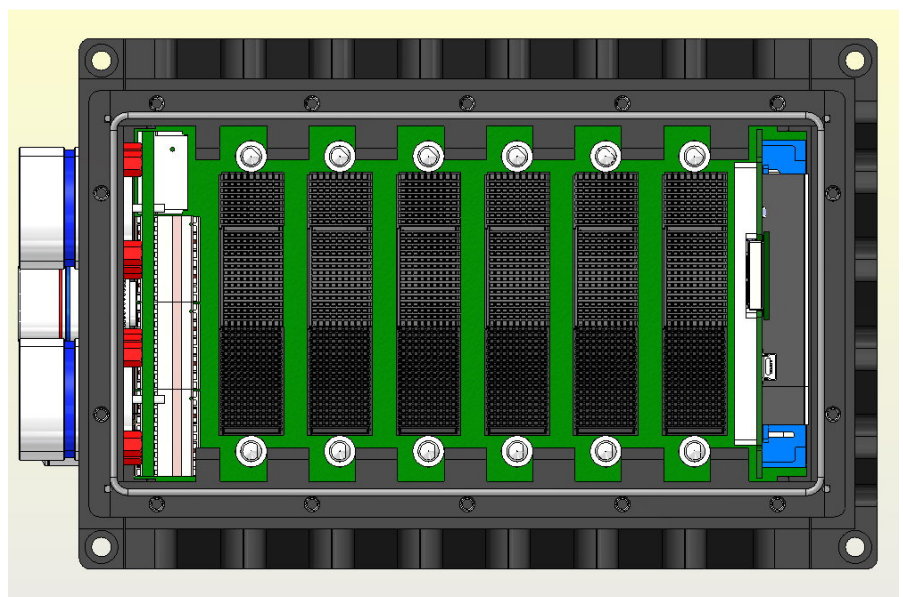

CCE-3VX6 Shown

Open Top View

Other Products from Dawn:

Card cages for commercial, aerospace and military applications
Enclosure 3D solid model design and production from commercial to full rugged military
Custom and Standard product PCB design, layout, production
RuSH™ Rugged system health monitor
Backplanes for **cPCI 2.1, cPCI 2.16, VME, VME64x, VXI, VXS, VPX, CUSTOM**, Build to Print
Powered Enclosures for Development, Prototype, Production, Deployment
Prototype Boards, Extender Boards, Form Factor Extenders
Front Panels, Filler Panels, Custom Panels, Build to Print Panels
Build to print machining, fabrication and assembly